

picture F-1

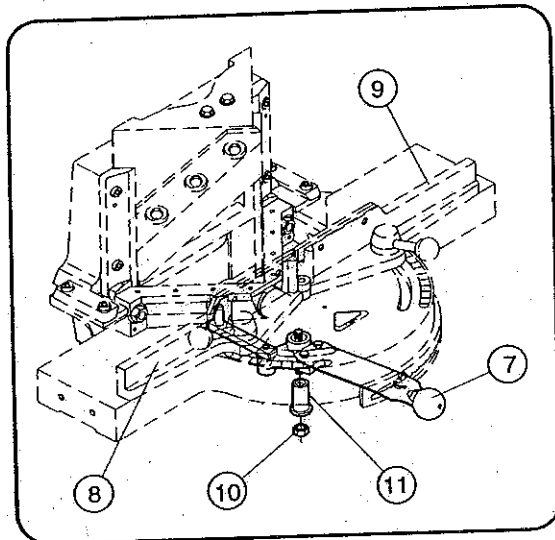

picture F-2

Regulation of Draw Bar

As the knives are worn it will be necessary to adjust the draw bar (1).

The following procedure is used:

1. The foot pedal (2) is pressed home and locked by means of the height stop (3).
2. Loosen nut (4).
3. The nut (5) is screwed so much upwards that the edges of the knives go about 4 - 6 mm under the upper side of the bottom knives.
4. Fasten nut (4) against the draw bow (6).

Adjustment of Forward Movement

When you have changed used knives it might be necessary to adjust the forward movement.

1. The knife block unit is placed in the front position with handle (7) (on the picture it is shown in the rear position). The fences (8) + (9) must be adjusted on standard (45°) position and be fastened.
2. Loosen nut (10).
3. Bushing (11) is turned with a spanner until the front point of the knives goes a little bit between the fences (8) + (9), but the knives must not touch the fences.
4. Fasten nut (10) while holding the bushing (11) in the adjusted position by means of the spanner.

The position of the knives is checked by moving the knife block down slowly. If the fences (8) + (9) are not touched, put a moulding in the machine and cut it. If the moulding does not split on the front edge the adjustment is correct.



Beware of the extreme sharp knives